

THE JOINT EXAMINATION BOARD

PAPER P6
INFRINGEMENT AND VALIDITY
TUESDAY, 30th OCTOBER 2007
10.00 a.m. – 2.00 p.m.

Please read the instructions carefully. **Time Allowed – FOUR HOURS**

1. You should respond to the instructions given at the end of the Client's letter.
2. Please note the following:
 - a. Enter the Paper Number (P6), and your Examination Number in the appropriate boxes at the top of each sheet of paper. Number the sheets of your paper sequentially;
 - b. The scripts are photocopied for marking purposes. Please write with a **dark inked pen** in the printed margins on one side of the paper only. Do not use highlighters in your answer;
 - c. Do not state your name anywhere in the answer;
 - d. Write clearly, as examiners cannot award marks to scripts that cannot be read;
 - e. **Marks are awarded for the reasoning displayed and the points selected for discussion rather than the conclusions reached.**
3. Under the Examination Regulations **you may be disqualified from the examination and have other disciplinary measures taken against you if:**
 - a. you are found with unauthorised printed matter or other unauthorised material in the examination room;
 - b. your mobile phone is found to be switched on;
 - c. you copy the work of another candidate, use an electronic aid, or communicate with another candidate or with anyone outside the examination;
 - d. you continue to write after being told to stop writing by the invigilator(s).
NO WRITING OF ANY KIND WILL BE PERMITTED AFTER THE TIME ALLOTTED TO THIS PAPER HAS EXPIRED.
4. **At the end of the examination sort your answer sheets into page number order and place them into the WHITE envelope provided.** Do not staple or fasten together the pages of your completed answer script in any way. Any answer script taken out of the examination room will not be marked.

Document checklist:

Client's letter:	(1 page)
Document A: Client's draft product literature and sketch	(3 pages)
Document B: EP Patent No. 0 314 159B	(5 pages)
Document C: GB Patent No. 271 828	(4 pages)
Document D: US Patent No. 6 022 142	(3 pages)

This paper consists of 17 pages in total, including this page.

5 Gordon Green is Technical Director of your client, Primrose Plastics Limited, a UK manufacturer of garden sprinklers, garden hose fittings and the like. He writes as follows:

10 "In September 2007 I came up with a new idea for a rainwater saving device, which I would eventually like you to patent for us. However I would first like you to comment on the results of some "quick and dirty" searches that I have done using the European Patent Office's very useful Espacenet® database. I found nothing that looks like my new device, which fits inside an existing drainpipe. But I did find some previous patents for rainwater savers that work in a similar way. They all intercept water running down the inside wall of a drainpipe and divert it through a side outlet that can be connected to a rainwater butt.

15 I know from past experience that patents can be tricky things. Before I invest in new manufacturing equipment I therefore need to be sure that these prior patents will not cause problems for my company. We are only interested in marketing our new product in the UK.

20 For your information I enclose a sketch of and draft product literature for the new device [Document A], which we want to publish when our patent application is on file. I also enclose copies of the prior patents concerned."

25 You check the UK patents register and find that EP 0 314 159 (Document B) is in force in the UK.

GB 271 828 (Document C) was filed in 1927.

From the US Patent and Trademark Office website you find that US 6 022 142 (Document D) lapsed through non-renewal in August 2003.

30 **Write a reasoned memorandum of advice setting out your client's (Primrose Plastics Limited's) position as to infringement of valid patent rights, solely on the basis of the documents and information given in the question above. Mention any further action that you think Nippon Rainwater Goods Co. Ltd. could take to improve its position. Discussion of the patentability of the client's product is not**

35 **required.**

SERPENTSAVA

5 The new SerpentSava rainwater saving device is designed to fit into a downpipe to divert rainwater into your rainwater butt, instead of letting this valuable natural resource go down the drain.

Main Technical Features and Benefits:

10

- EASY TO FIT – is housed within existing pipework (1) – no need for additional downpipe joints
- Compact size
- Self flushing – does not silt up
- Automatically controls the water level in your rainwater butt
- Open topped SerpentSava channel (3) catches and diverts water flowing down the inner walls of the downpipe during light to moderate rainfall
- Does not obstruct the downpipe significantly during heavy rainfall
- Resilient one-piece helical channel (3) adapts to fit within most downpipes
- Integral rubber bead (4) seals effectively to the downpipe inner wall
- Spigot (5) connects to rainwater butt (not supplied) using length of ordinary hosepipe (not supplied) and the included connector kit (6)

15

20

Fitting Instructions:

25

1. Locate your rainwater butt on a firm base where it can be permanently connected to the downpipe (1) by a short hose.
2. Mark a line on the downpipe 5cm below the level corresponding to the top of the butt.
3. Cut a 25mm diameter hole in the downpipe centred on this line, in a suitable position to connect the hosepipe.
4. Feed the channel (3) of the SerpentSava (2) through the hole so that it lies snugly against the inside of the downpipe. The flexibility of the SerpentSava allows it to be wiggled into position. Lubricate the rubber bead (4) with the supplied silicone grease to help insertion.
5. When the SerpentSava is correctly in position, the elbow (7) of the spigot (5) should butt up behind the top edge of the hole. Make sure that the channel (2) is the right way up, open top uppermost, and sloping continuously downwards towards the spigot (5). (The gradient is designed to be about 15 degrees to the horizontal in a 75mm downpipe).
6. Press down on the spigot to ensure that the shoulder (8) is firmly wedged behind the bottom edge of the hole.
7. Fit the curved sealing plate (9) over the spigot (5), rubber face (10) inwards. Screw on the clamping nut 11, finger tight.
8. Cut a corresponding 25mm diameter hole in the side of the rainwater butt, in the position where you wish to connect the hose. If the hose slopes continuously downwards from the downpipe to the rainwater butt, silt accumulation will be less. However, this is not essential, as the hose can be easily disconnected for cleaning. Locating the connector spigot (13) near the top of the rainwater butt means water will not discharge when the hose is disconnected.
9. Insert the butt connector spigot (13) through the hole from the inside, positioning one rubber sealing washer (12, 14) on either side of the butt wall. Screw on the clamping nut (15), finger tight.
10. Connect up the spigot (5) on the downpipe and (13) on the butt with the hose.

30

35

40

45

50

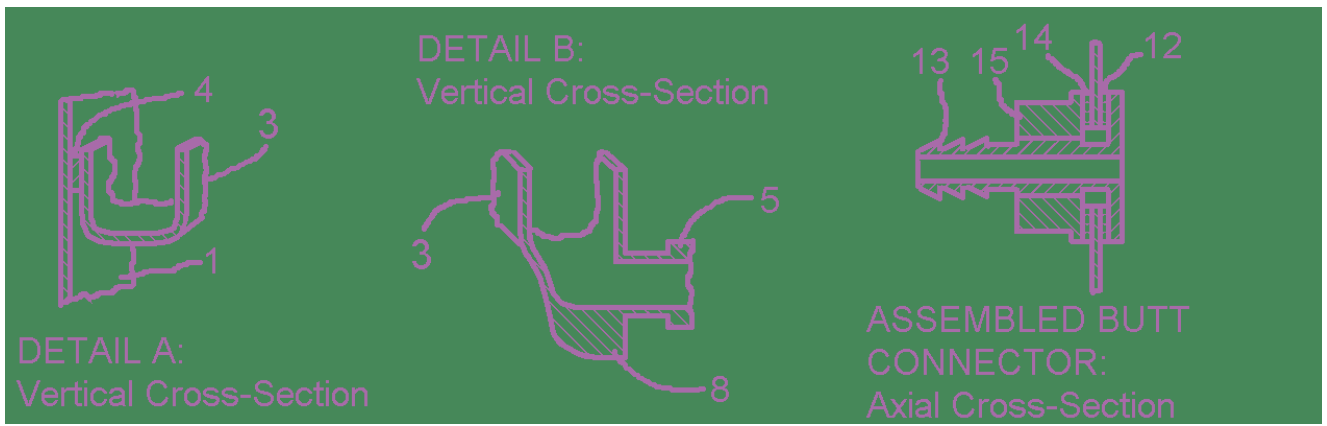
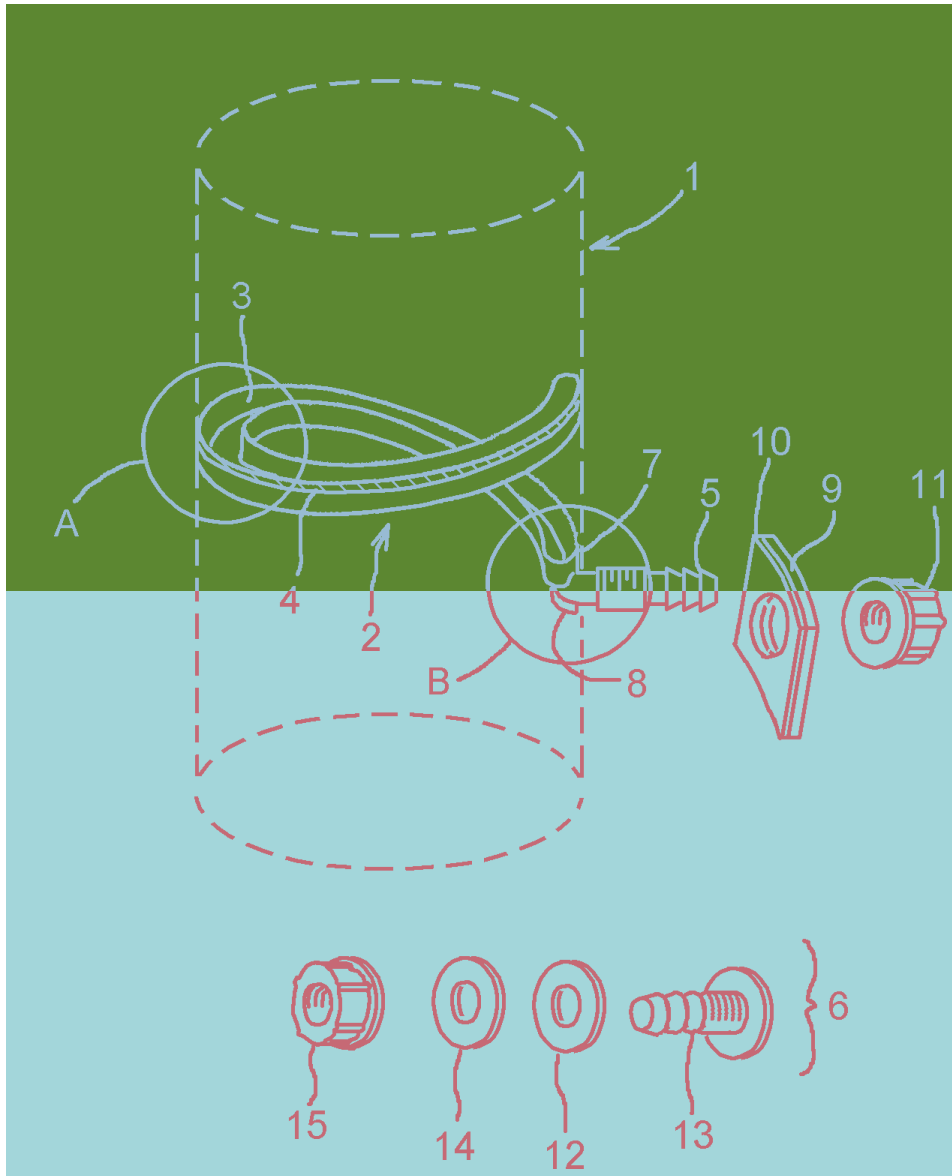

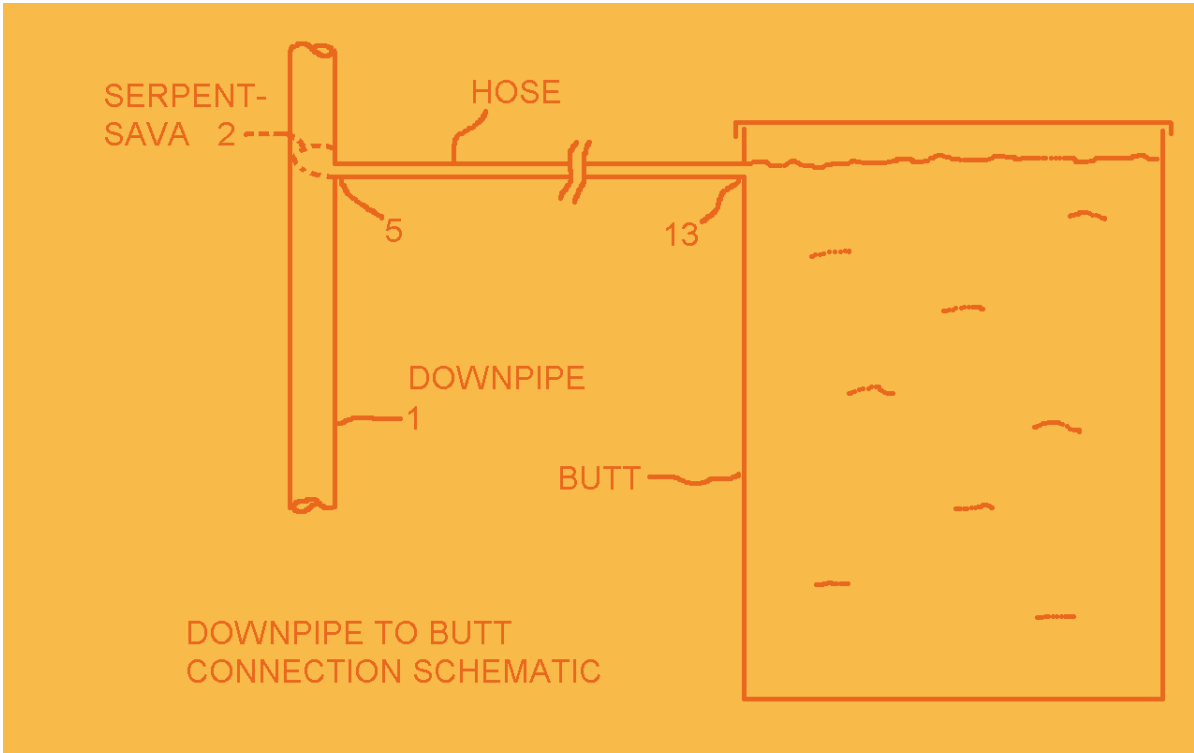



11 Publication number: **0 314 159 B1**

12 **EUROPEAN PATENT SPECIFICATION**

45 Date of publication of patent specification: **02.05.2005** 51 Int. Cl.⁵: **C08F 2/08, G03G 9/08**

21 Application number: **01117994.1**

22 Date of filing: **28.10.2001**

54 **Rainwater Catcher for a Rainwater Pipe**

30 Priority: **30.10.2000 JP 277068/2000**

43 Date of publication of application:
03.05.2002 Bulletin 02/18

45 Publication of the grant of the patent:
02.05.2005 Bulletin 05/18

84 Designated Contracting States:
DE FR GB IT

56 References cited:
GB-A-0 271 828

73 Proprietor: **Nippon Rainwater Goods Co., Ltd.**
2-1-2, Oyodokita Oyodo-ku
Osaka-shi Osaka-fu(JP)

72 Inventor: **Kagemusha, Akio**
3-24-12, Yamanoue
Hirakata-shi Osaka-fu(JP)
Inventor: **Yoshi, Chikaiyuki**
23-32, Kaminoguchi-cho
Kadoma-shi Osaka-fu(JP)

74 Representative: **King, Pat et al**
Ace IP LLP
100 Royal Mile
Edinburgh (GB)

Note: Within nine months from the publication of the mention of the grant of the European patent, any person may give notice to the European Patent Office of opposition to the European patent granted. Notice of opposition shall be filed in a written reasoned statement. It shall not be deemed to have been filed until the opposition fee has been paid (Art. 99(1) European patent convention).

Rank Xerox (UK) Business Services

EP 0 314 159 B1

The invention concerns a rainwater catcher for a rainwater downpipe, of the kind shown for example from GB271828. Such rainwater catchers are connected into rainwater downpipes, so as to be able to drain a part of the rainwater from the downpipe into a storage container, in order to have available a constant rainwater supply, e.g. for the watering of gardens or the like. The arrangement of a trough with an overflow wall causes draining away of rainwater to the storage container to stop automatically, as soon as the water level in the storage container reaches the height of the upper edge of the overflow wall. Further inflowing rainwater then runs out of the filled trough over the overflow wall into the downpipe. For this automatic control no moving parts are needed at the rainwater catcher or at the storage container. There are similar products on the market from a number of different manufacturers.

An objective of the invention is to improve a rainwater catcher of the kind indicated, in such a way as to obtain improved self cleaning, without impairment of the catching and draining away effects, and to present a smaller obstruction to the flow area of the rainwater downpipe.

The solution of this problem, and preferred features of the solution, are indicated in the claims.

A good self-cleaning action against dirt and deposits results from the sloping of the floor of the trough. Furthermore, as preferred, separating the trough into two trough parts offset from each other in elevation ensures that, especially with heavy rain water flow, a relatively large transverse cross section of the rainwater catcher housing remains available for disposal of surplus water, since the vertical gap between the two separate trough parts also serves to drain away water and in particular can drain away the water caught in the upper trough part.

An embodiment of the invention is described in greater detail with reference to the drawings.

Fig. 1 shows a broken away perspective view of the rainwater catcher, Fig. 2 shows the rainwater catcher in axial cross-section, and Fig. 3 is a perspective view of the floor and retaining wall of the upper trough part, shown separated from the catcher housing.

The rainwater catcher for a rainwater downpipe represented in Figs. 1 and 2 comprises a tubular housing 1, which is provided at an upper end with a sleeve-like expanded part 2 and at its lower end with a reduced diameter part 3 for connection to the rainwater downpipe. A trough 4a, 4b extending around the inner wall of the housing comprises half-tubular retaining walls 5a, 5b and a floor 6a, 6b connecting the retaining walls to the housing 1. The floor 6a and 6b of the trough 4a, 4b slopes, preferably at about 30° to the horizontal, as shown in the drawing, and in its deepest place communicates with a drain connection 7. The trough intercepts water flowing down the housing inner wall at all points around its circumference.

The trough is divided along one diameter of the housing 1 into two disconnected trough parts 4a and 4b each extending around half the circumference. The floor 6a of the trough part 4a is connected along the entire length of its outer edge 6c (Fig. 3) to the inner wall of the housing 1. The floor 6b of the trough part 4b is similarly connected to the inner wall of the housing 1. The two separate trough parts 4a, 4b are offset from each other in elevation in the direction of the centre axis of the housing 1. That is, the retaining wall 5a and floor 6a parts which belong to one trough part 4a, are offset in elevation from the retaining wall 5b and floor 6b parts which belong to the other trough part 4b. The deepest point of the sloping floor 6b is connected directly to the base of the drain connection 7 for draining away the rainwater into the storage container.

As can be seen from the drawings, a vertical gap 8 is developed between the two trough parts 4a, 4b. The vertical offset and the separation of the trough parts 4a, 4b makes possible a relatively

unobstructed cross-section of the catcher housing in the vicinity of the trough. In heavy rainfall this assists in disposing of surplus water through the downpipe section connected to the housing lower end.

5

Claims

1. A rainwater catcher for a rainwater downpipe, comprising:
a tubular housing (1);
10 a trough (4a, 4b) protruding inwards from the inner wall of the housing (1), the trough comprising a floor (6a, 6b) connecting to the inner wall and a retaining wall (5a, 5b) standing up from the inner edge of the floor; and
a drain connection extending outward through the housing wall in the vicinity of the floor of the trough,
15 characterised in that the floor (6a, 6b) of the trough slopes in the housing (1) towards the drain connection (7) which is arranged to extend from the vicinity of the deepest point of the sloping floor (6b).
2. A rainwater catcher according to claim 1 characterised in that the floor (6a, 6b) of the
20 trough lies at a slope of approximately 30° to the horizontal.
3. A rainwater catcher according to claim 1 or 2 characterised in that the trough extends substantially continuously around the inner wall of the housing and comprises parts (4a, 4b) diametrically opposed with respect to each other in the housing (1); the opposed parts being
25 vertically offset from each other.
4. Rainwater catcher according to claim 1 or 2 characterised in that the trough is divided into two disconnected parts (4a, 4b) vertically offset from each other so as to define a vertical gap (8) which provides an additional flow area for passage of rainwater between the upper and lower ends
30 (2, 3) of the tubular housing (1).

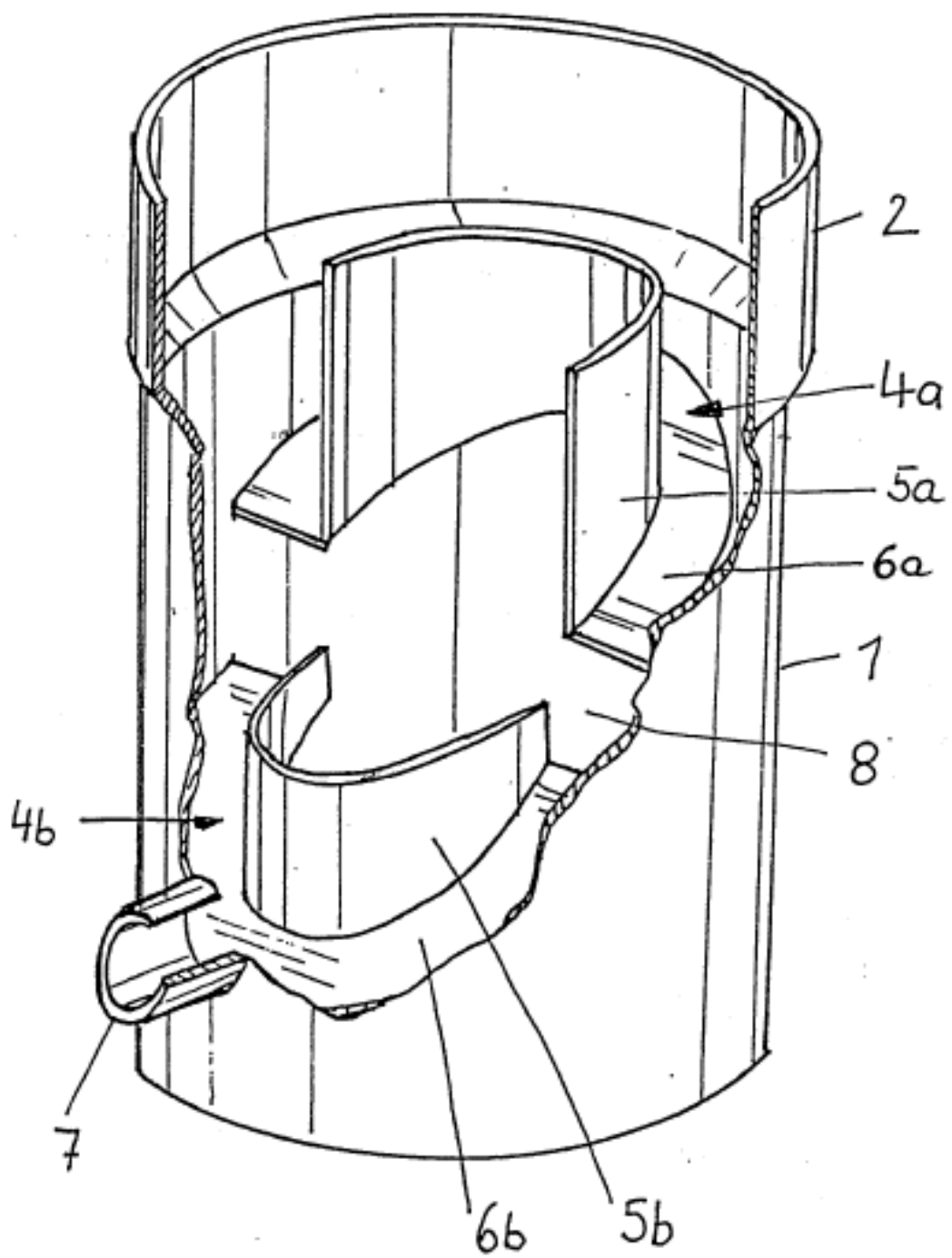

Fig. 1

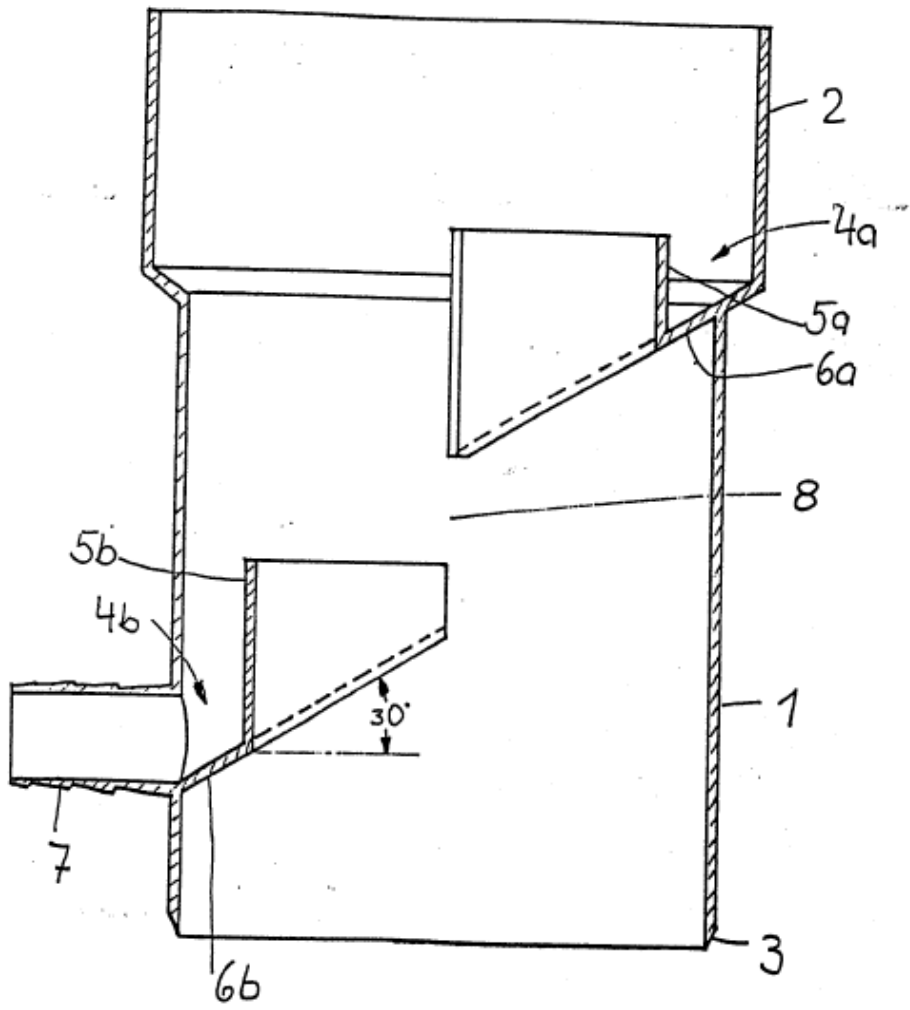

Fig. 2

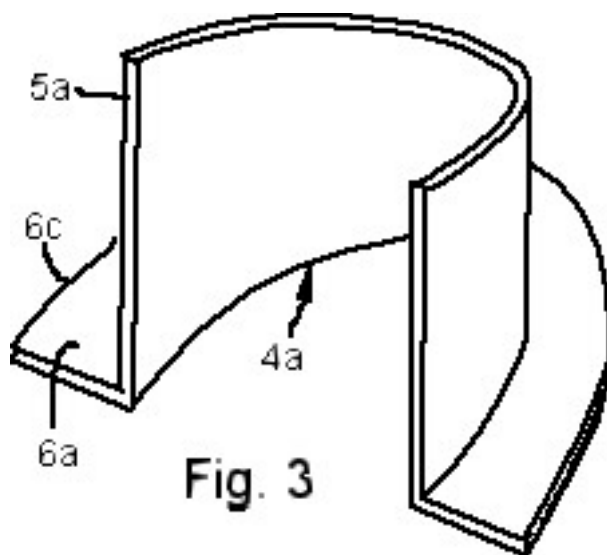
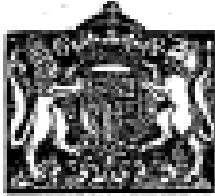

Fig. 3

PATENT SPECIFICATION**271 828**

Application Date March 25, 1927. No. 8300/27

Complete Accepted Dec. 1, 1927

10

COMPLETE SPECIFICATION

15

Improvements Relating to Water Use and Distribution

15

I, Donald Trenchfoot, of 11 Sunnyhill Avenue, Showerby, West Yorkshire a British Citizen do hereby declare the invention, for which I pray that a patent may be granted to me, and the method by which it is to be performed, to be particularly described in and by the following statement:-

20

At present water which may fall on the roofs of buildings in the form of rain or snow, is collected in guttering which runs along the edge of the said roofs. From the guttering the said drainage water is drained into the main drainage infrastructure below ground via a vertical pipe connecting the guttering to the ground. This therefore means that this water which is collected from the roof catchment area is lost with no use being made of said water. The current invention offers the ability to distribute this water to a desired location for use, on, for example, the garden.

25

30

The aim of the invention therefore is to provide a device whereby water passing along a pipe may be diverted from the said pipe to areas which may require the said water to be used. The present invention provides a distribution device connected into a pipe wherein at least part of the water passing through said pipe may be held in a reservoir formed within the device, said device providing means for the release of water from said reservoir to points external to the pipe.

35

The present invention therefore provides a water conservation device in or for a drain pipe which, when in the drain pipe, enables, without blocking the drain pipe, diversion of water from the drain pipe to a location other than the drain for use or for storage for subsequent use.

40

Preferably said device is fitted as an integral section of pipework with regular fittings.

45

45

One particular embodiment of the invention shall now be described with reference to the accompanying drawings wherein:

Figure 1 illustrates a typical installation and use of the device of the invention;
5 Figure 2 illustrates a cross sectional elevation of the device; and
Figure 3 illustrates a part sectional plan on A-A of the device as shown in Figure 2.

Referring now to the drawings and firstly with reference to Figure 1 there is shown the device 2 of the invention fitted to a typical building drainage system 4.
10 The device 2 incorporates a number of outlets 6 to which are connected a number of distribution pipes 8. The typical building drainage system 4 comprises an interconnected number of gutter lengths 10 leading to the main vertical drain pipe 12 into which there is fitted the distribution device 2.

15 Referring now to Figures 2 and 3 there is shown in greater detail the components which are required to form the distribution device 2. The outer wall 14 of the distribution device is formed of a pipe 16 which is typically of similar dimension to the pipework to which the device 2 is to be fitted. Located within the pipe section 16 there is mounted a second pipe 18 of smaller diameter. The ring-shaped
20 area 20 formed between the walls of the two pipes is sealed at one end 22, this in effect forming a reservoir area 24. The inner area of the second pipe 18 is open and allows water to pass therethrough in the direction 26 indicated.

In outer pipe 16 there is formed an outlet 6 through which water from the reservoir area 24 may pass.
25 The outlet 6 is in the form of a typical pipe connector 30 which will be sealed at 32 to prevent water leakage. To this outlet or a plurality of such outlets the distribution pipes 8 can be connected. When the outlet is not desired to be used, outlet stoppers (not shown) may be provided to prevent unwanted leakage from the reservoir area through the outlets.

30 The operation of the illustrated device commences with the collection in the gutters 10 of water which has fallen on the roof area as rain or snow. As this water drains from the roof so it enters the gutters and hence passes down the vertical drain pipe 12. When the water reaches the distribution device 2 in the pipe 12 the seal 22 prevents the water from passing further and hence the reservoir area 24
35 begins to fill. As the reservoir area 24 fills so the outlets 6 may be opened and water from the reservoir can be distributed via the distribution pipes 8 to those parts of the garden or building which require the water. If the amount of water passing through the device becomes so great that the reservoir area overflows, then surplus water can continue through the drainage system through the second
40 pipe 18 which acts as an overflow.

The reservoir 24 will fill up if flow through the outlets 6 is stopped in any way. This includes, for example, the case where an external storage tank or rainwater
45 butt (not shown) is arranged so that when it becomes full, water backs up through the pipework 8 connecting the storage tank to the respective outlet 6.

[Claims omitted]

- 1/2 -

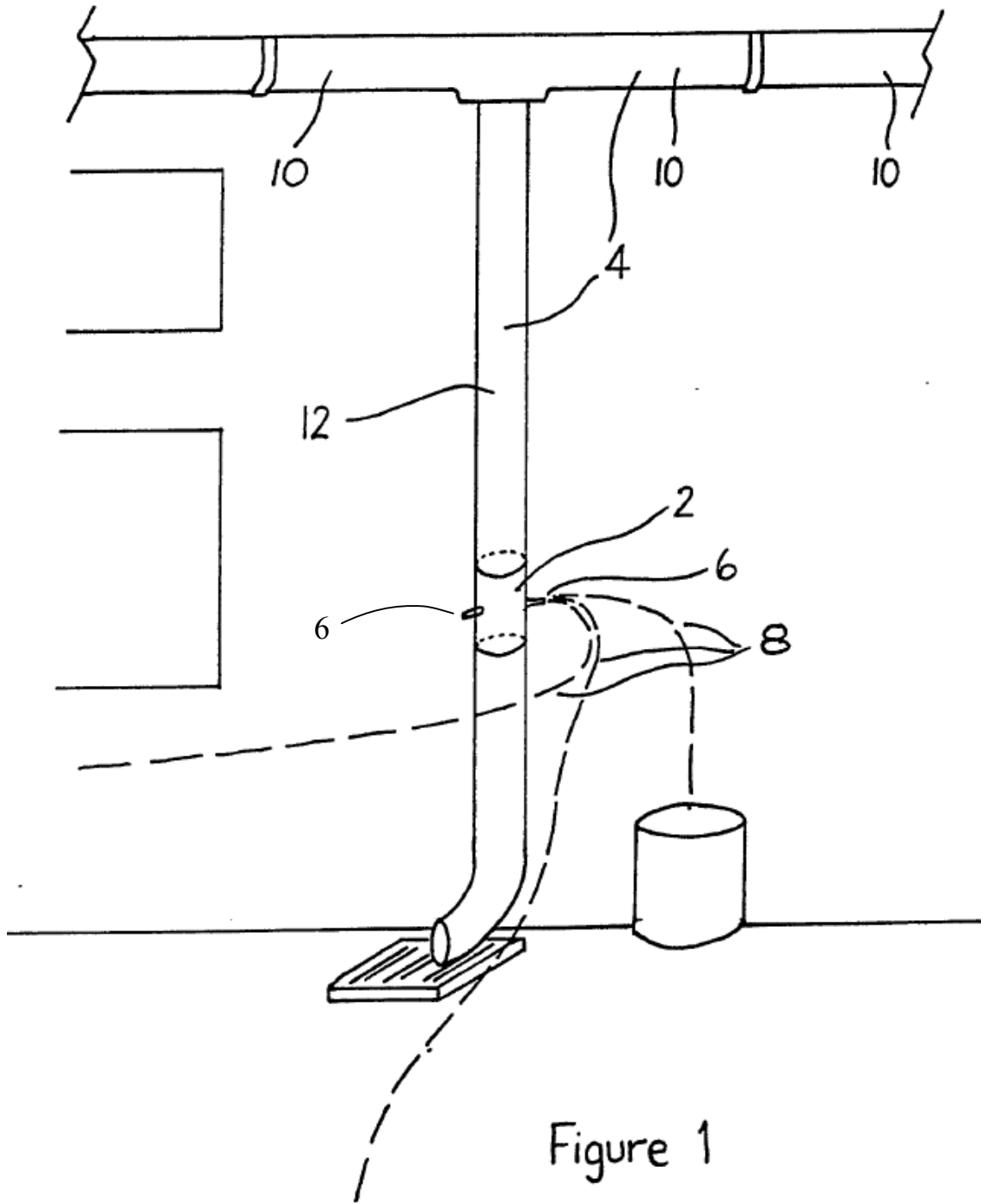

Figure 1

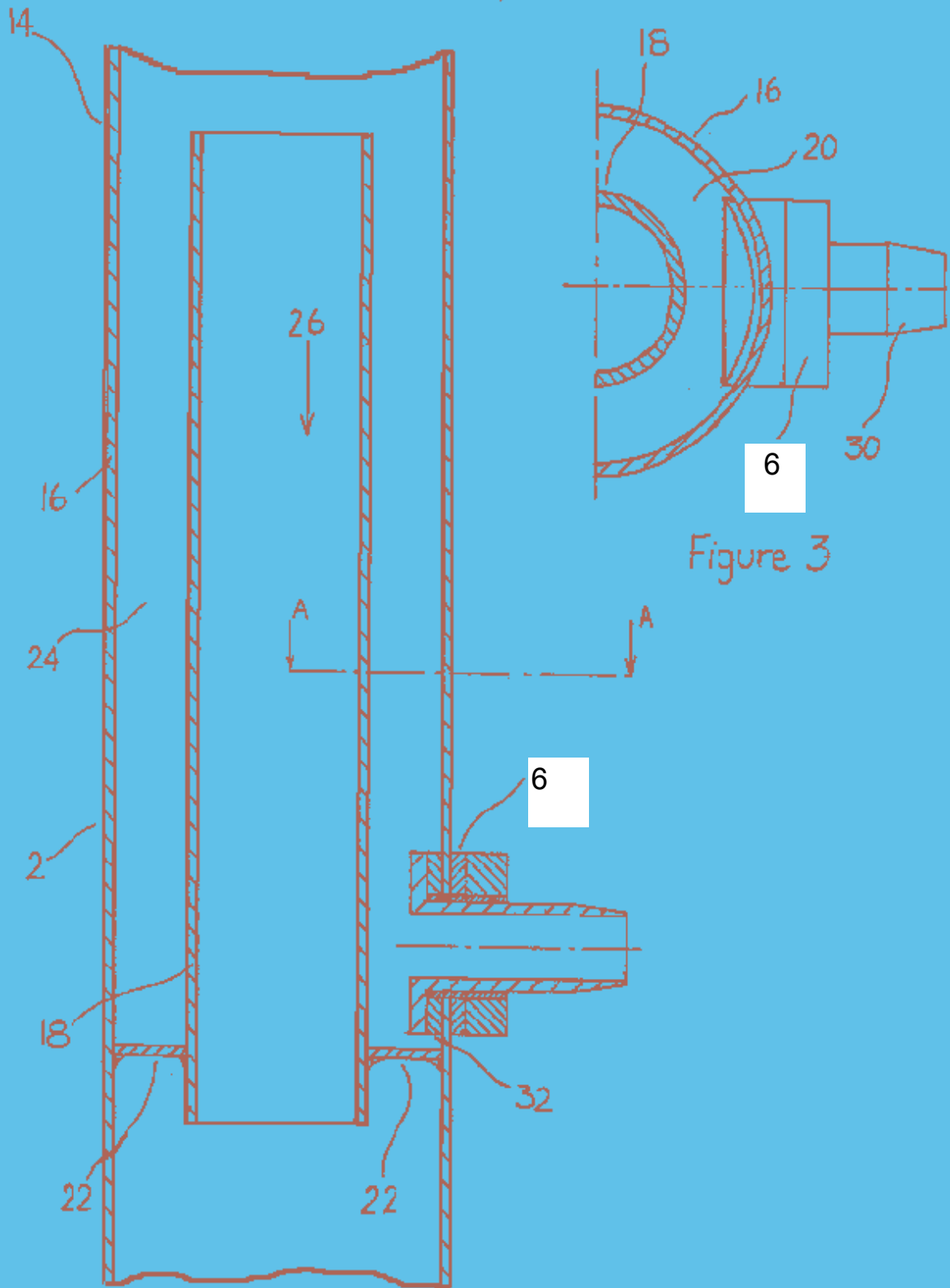

Figure 2

Figure 3



US006022142A

United States Patent [19]
Gurgler

[11] **Patent Number:** **6,022,142**

[45] **Date of Patent:** **Feb. 8, 2000**

[54] **IMPROVEMENTS IN OR
RELATING TO APPARATUS FOR
CONTROLLING THE FLOW OF LIQUIDS**

[75] Inventor: Frederick H. Gurgler, Atlantic City,
NY

[73] Assignee: NY Tube and Barrel Co., Inc., NY,
NY

[21] Appl. No. 08/848,509

[22] Filed Apr. 28, 1997

[51] Int. Cl.⁷G01K 7/16

[52] U.S. Cl.374/178

[58] Field of Search374/1, 172,
178-183; 374/185; 257-383

[56] **References Cited**

U.S. PATENT DOCUMENTS

None.

FOREIGN PATENT DOCUMENTS

271,828 12/1927 Great Britain

[57] **ABSTRACT**

Apparatus for controlling liquid flow under gravity comprises a liquid downpipe having vertically spaced sections **303**, **305**, a housing **301**, and a subsidiary outlet pipe **308**, the housing defining a collecting chamber having an inlet aperture **302** connected to the upper of said downpipe sections, a first outlet aperture **304** located vertically below the inlet aperture and connected to the lower of said downpipe sections, and a second outlet aperture **306** connected to said subsidiary outlet pipe, there being liquid flow pathways between said inlet and each of said outlet apertures, the housing including a deflector **309a**, **309b** locatable in said chamber preferentially to direct liquid emerging from said inlet aperture **302** into said second outlet aperture **306**, the arrangement being such that when there is resistance to liquid flow through said second outlet aperture, liquid is able to flow from said inlet aperture to said first outlet aperture **304**.

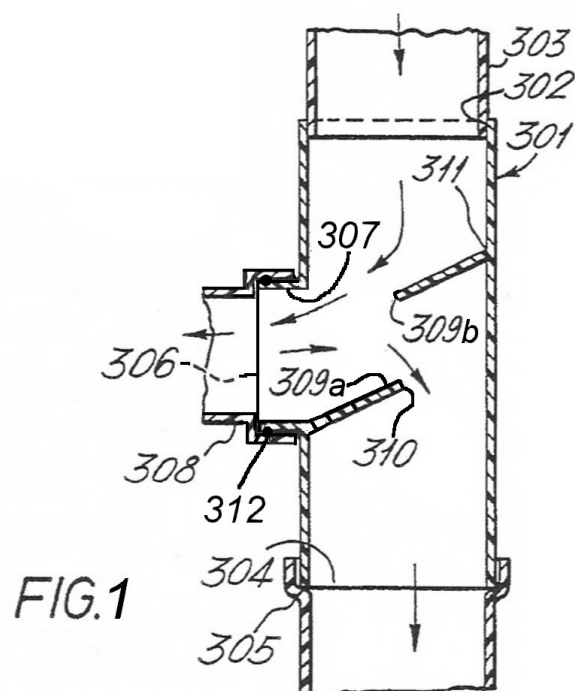

FIG.1

1

There is, from time to time, a requirement to fill a receptacle automatically and without supervision to a given level from a flow of liquid in a conduit, but to ensure that once the receptacle is filled to that level the liquid flow continues in the conduit alone and the liquid no longer flows to the receptacle. For example, there is such a requirement in the filling of domestic water butts from the flow of rainwater in downpipes, which commonly are connected directly to the waste water or sewage system. The invention provides liquid flow control apparatus capable of the required action.

A preferred embodiment of the invention will now be described by way of example only, with reference to the accompanying drawing in which:

Figure 1 shows a schematic vertical cross-section on a diameter of an embodiment of apparatus according to the invention, in combination with upper and lower sections of a rainwater downpipe.

As shown in Figure 1, a housing 301 is formed as a tubular element which is arranged vertically and has its upper end forming an inlet aperture 302 in which is received the lower end 303 of an upper pipe section of a rainwater downpipe and its lower end defining a first outlet aperture 304 which is surrounded by the upper end 305 of a lower section of a rainwater downpipe.

A second outlet aperture 306 is defined by a short tubular element 307 secured in a sidewall of the housing 301. An outlet pipe 308 leading to a receptacle (not shown) extends from the tubular element 307 and has its end connected to the tubular element 307 by a ring shaped seal 312. The interior of the tubular housing 301 defines a collecting chamber.

A deflector plate 309a, 309b extends across the housing 301 between opposed wall portions of the housing and is secured in a position to block the pathway between the inlet aperture 302 and first outlet aperture 304. The deflector plate consists of two separate parts 309a, 309b each inclined at about 25 degrees to the horizontal. The lowest point of part 309a is located adjacent and slightly below the mouth of the outlet pipe 308 and its upper edge 310 lies at a higher level extending substantially across a diameter of the housing 301. The lower edge of part 309b lies along substantially the same diameter but is vertically spaced above the part 309a. The highest point 311 of part 309b lies adjacent to the wall portion of the tubular housing 301 remote from the second outlet aperture 306.

2

In use water falls into the collecting chamber defined by the housing 301 through the aperture 302 and is deflected by the plate part 309b onto the plate part 309a and from the plate part 309a into the mouth of the outlet pipe 308 connected to the second outlet aperture 307 from the collecting chamber. If there is not resistance to water flow through the pipe 308, then water is preferentially directed down the outlet pipe 308 from the inlet aperture 302. If there is resistance to water flow down the pipe 308 because the receptacle is full, there is back pressure which causes the water to flow over the upper edge 310 of the deflector plate lower part 309a and through the first outlet aperture 304 into the upper end 305 of the lower section of rainwater downpipe.

The invention provides an unsupervised and automatic replenishment of a receptacle to a given level and ensures that any liquid surplus to requirements is directed in a safe and convenient manner down a disposal pipe.

[Claims omitted]

