

Final Diploma

FD3 Amendment of Specifications

Wednesday 13 October 2021

10:00 to 13:20 UK British Summer Time (GMT + 1 hour)

Examination time: 3 hours 20 minutes plus 10 minutes upload time

The 3 hours 20 minutes is allocated as follows:

10 minutes – Downloading and printing the question paper:

3 hours – Answering the questions:

10 minutes – Two screen breaks of 5 minutes each.

At 13.20 you MUST immediately stop answering the questions. You then have **10 minutes** in which to upload your Answer document to the PEBX system.

You MUST upload your Answer document to the PEBX system by 13.30. After 13.30 you will not be able to upload it and your examination will be void.

INSTRUCTIONS TO CANDIDATES

1. The whole assessment task is to be attempted.
2. The marks to be awarded are given at the end of the assessment task.
3. The total number of marks available for this paper is 100.
4. Start each part of your answer on a new sheet of paper.
5. You must use the Answer document for your answers.
6. Do not attempt to change the font style, font size, font colour, line spacing or any other pre-set formatting.
7. Start each part of your answer on a new page. Press the control key and the enter key simultaneously to begin a new page.
8. Do not state your name anywhere in the answers.
9. This question paper consists of **23 sheets**, including this sheet, and comprises:
 - Assessment task (1 sheet)
 - Client letter (1 sheet)
 - Document A Examination Report (1 sheet)
 - Document B Client application 1818181.8 (9 sheets including 2 sheets of drawings)
 - Document C Prior art reference D1 – US 3,443,443 (3 sheets including 1 sheet of drawings)
 - Document D Prior art reference D2 – US 4,123,123 (5 sheets including 3 sheets of drawings)

A spare set of Claims of the patent application 1818181.8 for you to annotate and include in your answer if you wish (2 sheets).
10. A spare set of Claims is also provided in your Answer document for you to use if you wish.

AT THE END OF THE EXAMINATION

11. **Save your Answer document to your computer as a Word document. Convert the Answer document to a PDF. Check the Answer document to make sure that amended Claims are shown as you want in the Answer document. Upload the PDF-ed Answer document to the PEBX system.**

Assessment task

You have received the letter and documents listed on the Instructions to Candidate sheet regarding United Kingdom patent application number GB 1818181.8, which has been filed at the UK Intellectual Property Office with no claim to priority, and was published in 2019.

Your task is to prepare:

1. a letter to the UK Intellectual property Office in response to the Examination Report;
2. a set of amended claims, if considered necessary;
3. notes on which you would base advice to your client in which you:
 - i. explain the actions you have taken;
 - ii. provide full reasoning for your actions;
 - iii. outline future actions, if any, that your client could take to secure full protection of its commercial interests.

Your advice should take into account that further information may be required.

Your notes should only relate to the invention(s) outlined in the client's correspondence to you.

Your notes should be directed to patent matters only.

Note the following:

- a) You are NOT required to make any amendments to the description of the client's patent application.
- b) You should accept the facts given to you and base your answer on those facts.
- c) You should not make use of any other special knowledge that you may have of the subject matter concerned.
- d) You should assume that the prior art referred to is complete.
- e) You should identify clearly any amended claim set and/or divisional claim(s).

Allocation of Marks

Letter: 37 marks
Claims: 35 marks
Notes: 28 marks
Total: 100 marks

Client letter

Brain Drain Ltd

Barrel Patent Attorneys

Dear Mr Barrel,

I wonder whether you can help. I have prosecuted this application myself so far but don't know how to deal with the Examiner's objections.

I have a small business dealing in plumbing accessories. I was looking to improve the currently available range of devices for unblocking drains, sinks, toilets and so on, when I came up with my idea of using the water pressure from a nearby tap. It seems that others have had similar ideas, but I think mine has its advantages. In particular, it will unblock a toilet, which the standard round cup-shaped plunger cannot easily do because it does not seal well against the drain outlet. The D2 document claims to be able to do this, but my design doesn't need a source of compressed air.

In D1, the check valve in the bottom of the handle 10 has a small flow cross-section, and so considerably restricts the available flow from the tap. It is only there so that, if the user attempts to reinforce the action by pushing down on the hand grips, the valve closes and the device is essentially the same as a conventional rubber plunger. My construction is simpler and doesn't restrict the flow at all.

As far as D2 is concerned, it is a complex mechanism and I can't see it being used in a domestic setting. It looks as though it would be tricky to operate with water – in theory I suppose you could pressurise air in the pressure ball by forcing water through the valve 33, but the pipework and valves are all configured for air supply and so are too small to allow water to flow fast enough. Also, it would be difficult to clear all the water afterwards, so I suspect the parts would be vulnerable to mould build-up or corrosion. I could also imagine that the valve with its valve seat at the end of a long unsupported rod might not always align and seal properly, and I expect would be vulnerable to damage or premature failure. Our design does not have a ball so is not as bulky.

I don't understand the Examiner's objection to the wording of claim 7.

Please do whatever is needed to overcome all the objections and send me a draft to check before sending it to the Examiner.

Yours sincerely,

Clara Waterman (Mrs.)

Document A – Examination Report

Intellectual

Property

Office

Your ref:		Examiner:	Wayne Dwayne
Application no.	1818181.8	Tel:	01633 818181
Applicant	Brain Drain Ltd	Date of report:	15 July 2021
Latest date for reply:	15 November 2021	Page	1/1

Patents Act 1977

Examination report under Section 18(3)

Basis of the examination

1. The examination has been carried out on the basis of the application as filed.

Novelty

2. The invention as claimed in claim 1 is not new in view of D1, which has a hemispherical drain sealing member 21, an elongate pipe 10, a side arm 15 and a valve 23/24/28 in the end of the pipe which controls fluid flow to the inside of the sealing member 21. It is also not new in view of D2, with drain sealing member 6, pipe 5 (or 5 + 3), side arm 33 and valve 45/52.
3. Claims 4–6 and 8 are also not novel (plastic or metal pipe 10 of D1, page 13 lines 27–28; judging from the application of the device, the length of the pipe is likely to fall within the range given in claim 5; coupling 17 in D1 anticipates claim 6).

Inventive Step

4. Even if a point of novelty could be identified in claim 1, the claim is not inventive in view of the disclosures of D1 and D2, both of which are for clearing blocked drains: slight differences in the shape and arrangement of components in D1 do not change the function of the device; in D2 there is nothing to prevent connection of a pressurised water supply rather than an air supply.
5. Further, claims 2, 3 and 6–8 are not inventive: the drain sealing members 21 and 6 in D1 and D2, respectively, are resiliently compressible, preferably of rubber, and rigid bases for rubber sealing members are well known, e.g. the closure 28 in D1; the valve 45/52 in D2 is operable by the user by the lever 2 to move the rod 4 against the spring 43.

Conciseness, Clarity and Support

6. There is no antecedent for the ‘stem’ in claim 7.

Client application

GB 1818181.8

DRAIN UNBLOCKER

FIELD OF THE INVENTION

This invention relates to a drain-clearing device. More particularly, this invention relates to a drain-clearing device
5 for drains having an opening which is submerged or relatively inaccessible.

BACKGROUND OF THE INVENTION

Various techniques have been known for clearing clogged basins in drainage systems such as in a sink or toilet. For example,
10 use has been made of chemical compositions and mechanical devices, such as plungers, elongated wire springs commonly known as snakes, and the like. However, chemical compositions are generally only effective against certain types of drain clogging materials and tend to cause corrosion or damage to the
15 drainage system when used frequently. Mechanical devices, such as plungers, are frequently not effective for badly blocked drains, and snakes are difficult to use, and frequently necessitate professional assistance. Other mechanical devices have also been known that have a drain unblocking member
20 connected to a plunger and a water supply device. However, in use, the device must be held by hand or on a supporting rod. As a result, the device is difficult to use in clearing drains where the drain opening is submerged or relatively
25 inaccessible, as the supporting rod tends to slip and an effective seal cannot be readily maintained. Further, if used by hand, the result may well be most unpleasant to the user, particularly where the drain water is dirty.

Accordingly, it is an object of the invention to provide a relatively simple and effective device for clearing drains.

Document B

It is another object of the invention to provide a drain-clearing device which can be manipulated from a position remote from the drain to be cleared, so that the user does not have to be in contact with dirty drain water.

- 5 The drain-clearing device should also be simple and economical to manufacture.

SUMMARY OF THE INVENTION

The invention provides a drain-clearing device which includes a hemispherical sealing member for sealing a drain opening and
10 having a passage extending through it, and a water supply device having an elongate pipe secured to the sealing member and aligned with its passage, a side arm extending from and communicating with the pipe at a point remote from the sealing member to supply water to the pipe, and a valve to control the
15 flow of water selectively from the side arm into the pipe.

The sealing member is made of a resiliently compressible material to seal against and around a drain opening and may be backed by a solid annular (ring-shaped) supporting member.

The side arm is connectable via a water hose or the like to a
20 source of water pressure, such as a tap (or 'faucet') of a household or industrial water supply system, to receive a flow of pressurised water and deliver it into the pipe.

The valve, called a plunger valve, typically comprises a hollow stem with a port, a knob, or at least a closed top end, and a
25 spring around the stem. The stem is slidably mounted in the pipe so that in an extended position the stem blocks the side arm from the pipe so that water cannot flow into the pipe, whereas in its depressed position the stem aligns the port with the side arm so that water can flow into the pipe and thus into
30 the drain. The knob in this embodiment is circular in section and rounded in profile. It is placed at one end of the stem to abut against the end of the pipe when pushed down, preventing the stem from passing completely into the pipe. The spring is

Document B

placed around the stem in abutment with the pipe for urging the stem back out of the pipe to the extended position.

Pressure applied downwardly on the knob activates the plunger valve, pushing the valve stem from the extended (closed)

5 position to the depressed (open) position, where the port is in communication with the side arm on the pipe.

In use, to clear a clogged drain, the drain-clearing device is connected to a suitably located water tap by a hose, for example via threaded couplings, though compression or other

10 couplings could also be used. The sealing member of the drain-clearing device is then positioned in place via the elongate pipe and held firmly against the drain opening to create a seal. The tap is then turned on and the plunger valve activated by a downward push on the knob. Water from the tap thus flows

15 through the side arm, the pipe and the drain sealing member into the drain. The pressure of the water is thus utilised to dislodge drain-clogging materials.

BRIEF DESCRIPTION OF THE DRAWINGS

FIG. 1 illustrates a schematic view of a drain-clearing
20 device in use in accordance with the invention; and

FIG. 2 illustrates a cross-sectional view of the device.

Referring to **FIG. 1**, the drain-clearing device comprises a solid hemispherical drain sealing member 1 and a water supply part 5.

25 The drain sealing member 1 is made of a resiliently compressible material, such as rubber, and is adapted to seal against a drain opening 21 which is submerged under the level of water 23, for example in a toilet bowl 22. The drain sealing member 1 can be made in different sizes and shapes for

30 different drain openings and, as shown in **FIG. 2**, has a flat base or backing 1', and a central passage 15 for a through-flow of water. The drain sealing member 1 is fixedly attached to a round, solid, disc-like, annular member 2, made of a hard

Document B

material, such as plastic or metal, which provides a firm backing for the sealing member 1. In addition, a tube 3 with a cup-shaped internally threaded part 4 at its upper end extends through the centre of the sealing member 1 and annular member 2, forming the central passage 15.

The water supply part 5 comprises an elongate pipe 13 made of pressure-resistant material, such as plastic or metal, with a side arm 10 and a plunger valve 6 mounted at the upper end of the pipe 13, i.e. remote from the drain. The pipe is typically at least 20 cm long, up to about 60 cm.

The elongate pipe 13 is removably mounted in the sealing member 1; to this end the pipe is externally threaded at one end (the lower end) 12 and is screwed into the cup-shaped threaded part 4 in the sealing member 1, forming a continuous passage with the tube 3 in the sealing member.

The side arm 10 is integral with the pipe 13 and has a passageway 14 communicating with the interior of the pipe 13. As shown, the side arm 10 extends at an upward angle from the pipe 13 for a short distance and has a threaded end 11.

The plunger valve 6, mounted in the upper end of the pipe 13, enables communication between the side arm 10 and the pipe 13. As shown in FIG. 2, the valve 6 includes a tubular body or stem 6' with a port 6'', i.e. a hole in the side of the tube, a knob 7 and a spring 9. The diameter of the port 6'' is at least as great as the internal diameter of the side arm 10. Although not shown in the drawing, the stem 6' can have a longitudinal rib engaging in a corresponding groove in the interior of the pipe 13, or vice versa, to prevent the stem rotating and thus ensure that the port 6'' always lines up with the side arm 10 when the plunger is depressed.

The stem 6' is slidably mounted in the pipe 13 to move from an upper extended position 8a to a lower depressed position 8b (dashed line) under a manual force applied on the knob 7. In this lower position, the port 6'' is aligned with the side

Document B

arm 10 so that the passage 14 in the side arm 10 communicates with the pipe 13. The knob 7 is at the upper end of the stem 6' and stops the stem 6' from passing completely into the pipe 13. The spring 9 is positioned around the plunger stem 6' and abuts
5 the end of the pipe 13 to return the stem 6' from the lower position 8b to the upper position 8a when pressure is released from the knob 7.

In use of the device, referring to FIG. 1, the side arm 10 is coupled to a conventional water tap 24 by a hose 20 via a
10 threaded coupling at both ends of the hose 20. The drain sealing member 1 is held firmly over the clogged drain opening 21 to create a seal. The tap is then turned on and the plunger valve 6 is activated by pushing the knob 7 downward. It is advantageous that the system is operated by the knob and not
15 the tap, especially if the tap is some way away from the drain.

Water then passes through the hose 20 and side arm 10, via the port 6'', into the pipe 13 and downwardly through the central passage 15 of the sealing member 1 into the drain. Water
20 pressure from the tap 24 is transmitted into the drain to clear it. The pressure applied downwardly by pressing the knob 7 also helps to maintain a seal around the drain sealing member 1 and the drain opening. The knob may be pumped to apply a pulsed pressure to the drain. In some embodiments the spring 9 is not
25 needed as the user returns the knob and valve to the upper position.

The material of the drain sealing member 1 is of sufficient resiliency that, when it is pressed against the drain opening, an effective seal is created. The sealing member can be of circular (horizontal) cross-section, for simple drain profiles,
30 or it can be of a more specialised, but still solid and convex, shape, perhaps of oval section, suitable for some toilet bowls. A set of profiled shapes can be provided with the basic water supply part 5 and exchanged as needed. The device is of simple construction and easy to use.

Document B

CLAIMS

1. A drain-clearing device comprising: a hemispherical drain sealing member (1) with a central passage (15), for sealing against a drain opening; and a water supply device (5) having an elongate pipe (13) secured to the sealing member and communicating with the central passage in the sealing member, a side arm (10) extending from an end of the pipe remote from the sealing member and communicating with the pipe for supplying water thereto, and a valve mounted in the pipe to control flow of fluid between the side arm and the central passage.
2. A drain-clearing device according to claim 1, in which the hemispherical drain sealing member (1) is made of resiliently compressible material for sealing against the drain opening and is fixedly attached to a solid, disc-like, annular member (2) with a threaded aperture aligned with the central passage (15).
3. A drain-clearing device according to claim 2, wherein the drain sealing member is made of rubber.
4. A drain-clearing device according to any preceding claim, wherein the elongate pipe (13) is made of plastics or metal.
5. A drain-clearing device according to any preceding claim, wherein the length of the pipe is in the range of 20-60 cm.

Document B

6. A drain-clearing device according to any preceding claim, wherein the side arm (10) has a thread for connection to a hose to be attached to a water supply.
7. A drain-clearing device according to claim 1, further comprising a spring (9) positioned around the stem (6') of the valve and in abutment with the end of the pipe for urging the stem out of the pipe.
8. A drain-clearing device according to claim 1, in which the valve is operable by the user to admit water.

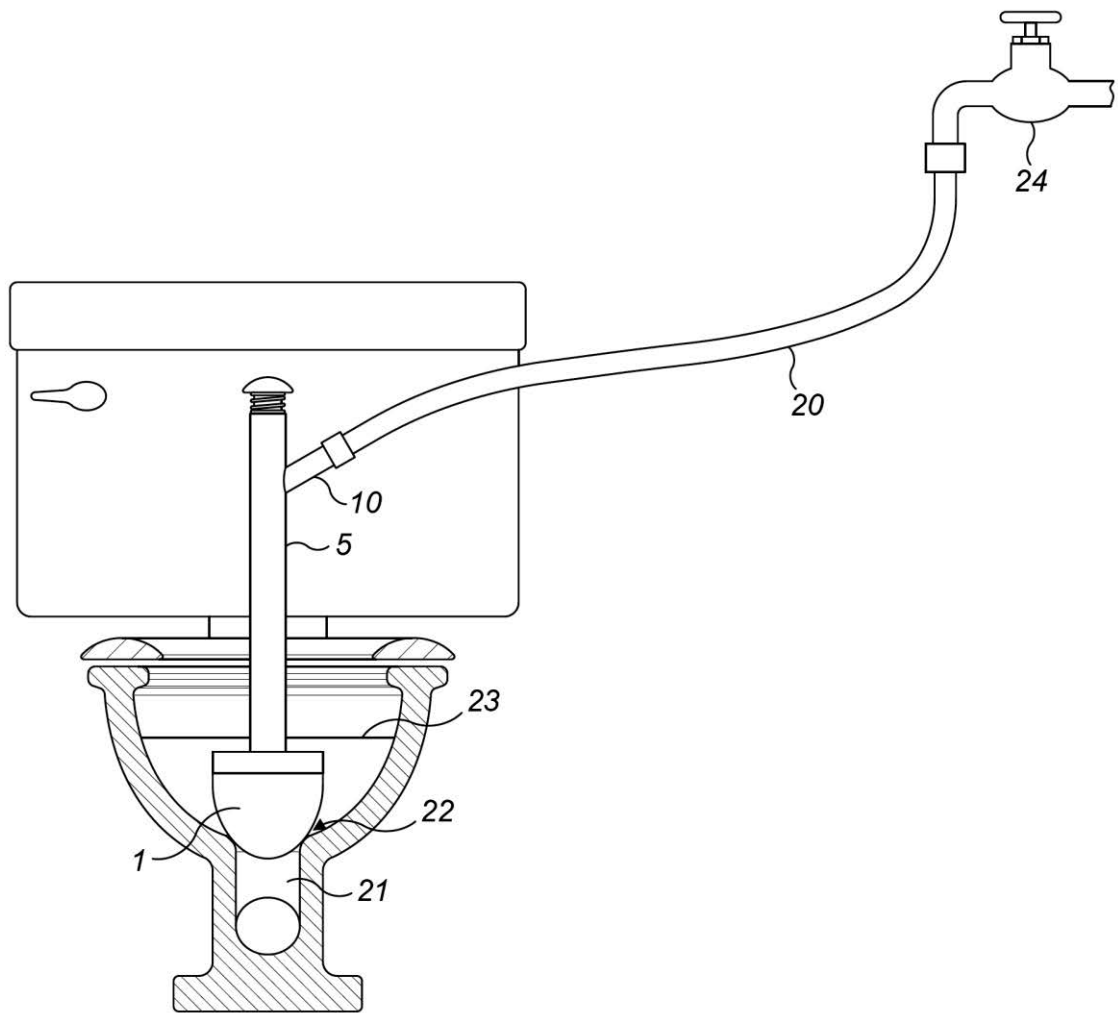

FIG. 1

2 / 2

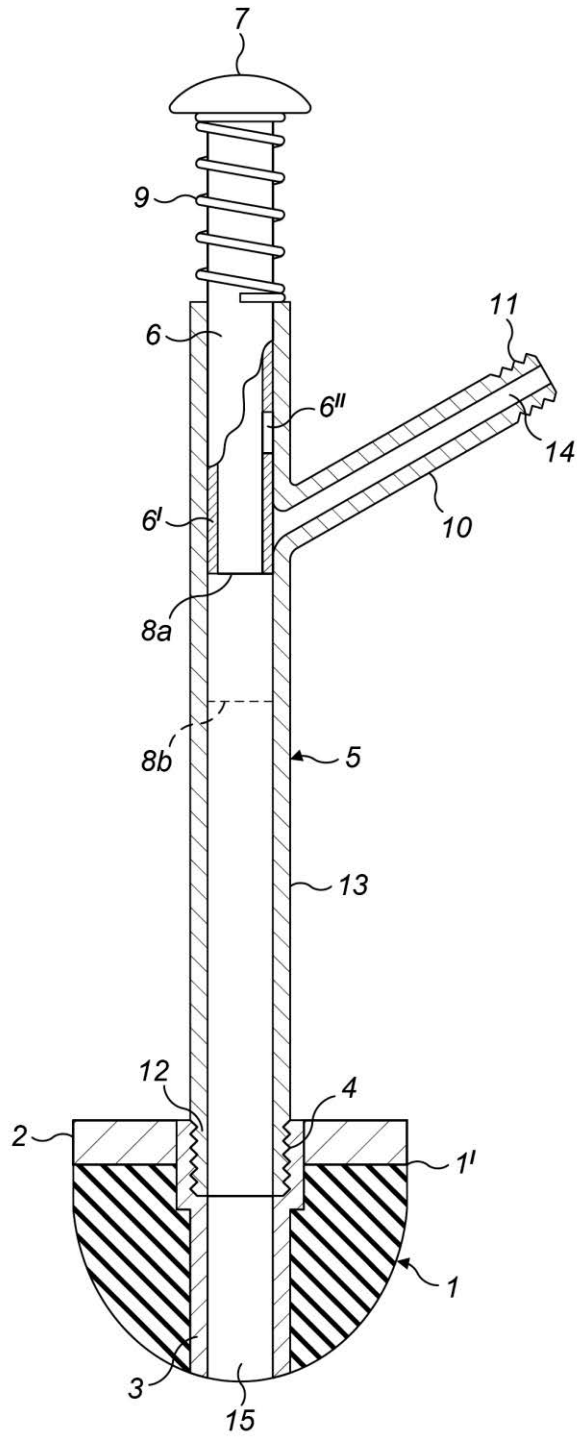

FIG. 2

Document C

Prior art reference D1

US 3,443,443

Granted September 18, 1968

HYDRAULIC CLEAN-OUT DEVICE

This invention relates to a hydraulic cleanout device adapted to be used in cleaning outlets from sinks and the like.

5 An object of the invention is to provide an improved clean-out device that is easy to use and does not demand excessive exertion on the part of the user. The device has a handle and a dome-shaped rubber cap thereon adapted to be placed over the drain or outlet from the sink and to provide the device with a spring adapted to engage and be compressed against the strainer over the drain. By the improved construction, when the handle is forced downwardly, flexing the cap, some fluid is forced through the drain.
10 On releasing the handle, however, as some fluid has been forced through the drain the cap will not immediately return to its normal position because of the partial vacuum formed therein.

The presence of the spring serves to assist the cap returning to normal position so that the handle may be easily and quickly reciprocated (i.e. pumped up and down), causing
15 the fluid in the drain to be agitated and forced through the drain sufficiently to readily clean the drain.

The hydraulic clean-out device for sink drains and the like also includes a construction for conveying fluid such as water under pressure to the interior of the handle to be discharged through the cap into the drain. A check valve may be provided in the handle
20 so that reverse flow through the handle is effectively prevented while the cap is being flexed under downward movement of the handle. Conveniently the construction enables the user to force the handle downwardly to force the fluid through the sink drain.

For a fuller understanding, reference will now be made to the accompanying drawings,
25 in which the single figure is a view in vertical section illustrating the improved hydraulic clean-out device in its applied position.

The improved device comprises a hollow handle 10 which may be formed of metal or plastic pipe and which has its upper end closed as indicated at 11.

Laterally extending hand grips are provided on the handle, one hand grip being

Document C

indicated at 12 having a closed outer end 13 and having its inner end threadedly connected as at 14 to the handle 10. The other hand grip comprises a short open section of pipe indicated at 15 having its inner end threaded into the handle 10 as at 16 and having its outer end open and adapted to receive the coupling member 17 on a
5 hose 18, e.g. by way of a screw fitting. The hose 18 is adapted to be connected by a coupling member 19 to the water faucet 20.

On the lower end of the handle 10, there is secured a hollow hemispherical or dome-shaped rubber cap 21 and within this cap there is a coil spring 22 which is approximately equal in length to the distance from the top of the cap to its bottom. This
10 spring is secured to the underside of the cap at the top. Within the lower end of the handle there is threadedly mounted a valve cage 23, having ports or water channels 24. A base 25 is screwed into the bottom of the valve cage. The base 25 has downwardly convergent ports 26 formed therein which merge into a single port discharging through the top of the cap 21. The base 25 has an upwardly extending
15 stem or shaft 27 which extends centrally through an aperture in the top of the cage 23. A valve closure 28, formed of a rubber washer fixed to a metal backing plate or washer, slides freely up and down on this shaft to close and open the ports 24. This valve closure constitutes a check valve preventing reverse flow through the handle.

The operation of the device is as follows: When the drain D of the sink S becomes
20 clogged, the hose 18 is connected to the faucet 20. The handle 10 is then manipulated to position the cap 21 over the strainer S' on the drain D, the handle 10 being near the faucet. While holding the handle 10 down, the faucet can be turned on, causing the water to flow through the hose 18, the hand grip 15, the handle 10 and the check valve and be discharged through the cap 21.

25 If the water pressure is insufficient to force the obstruction through the drain D, the operator may grasp the hand grips 12 and 15 and force the handle downwardly. This flexes the cap 21 and compresses the spring 22. Reverse flow through the handle is prevented by the check valve in the lower end of the handle 10. If necessary, the operator can pump the handle, developing sufficient pressure or agitation within the
30 drain D to dislodge the obstruction. Because the coil spring 22 is compressed, it assists the cap 21 returning to its normal shape, overcoming the effect of the partial vacuum produced therein.

(Claims omitted)

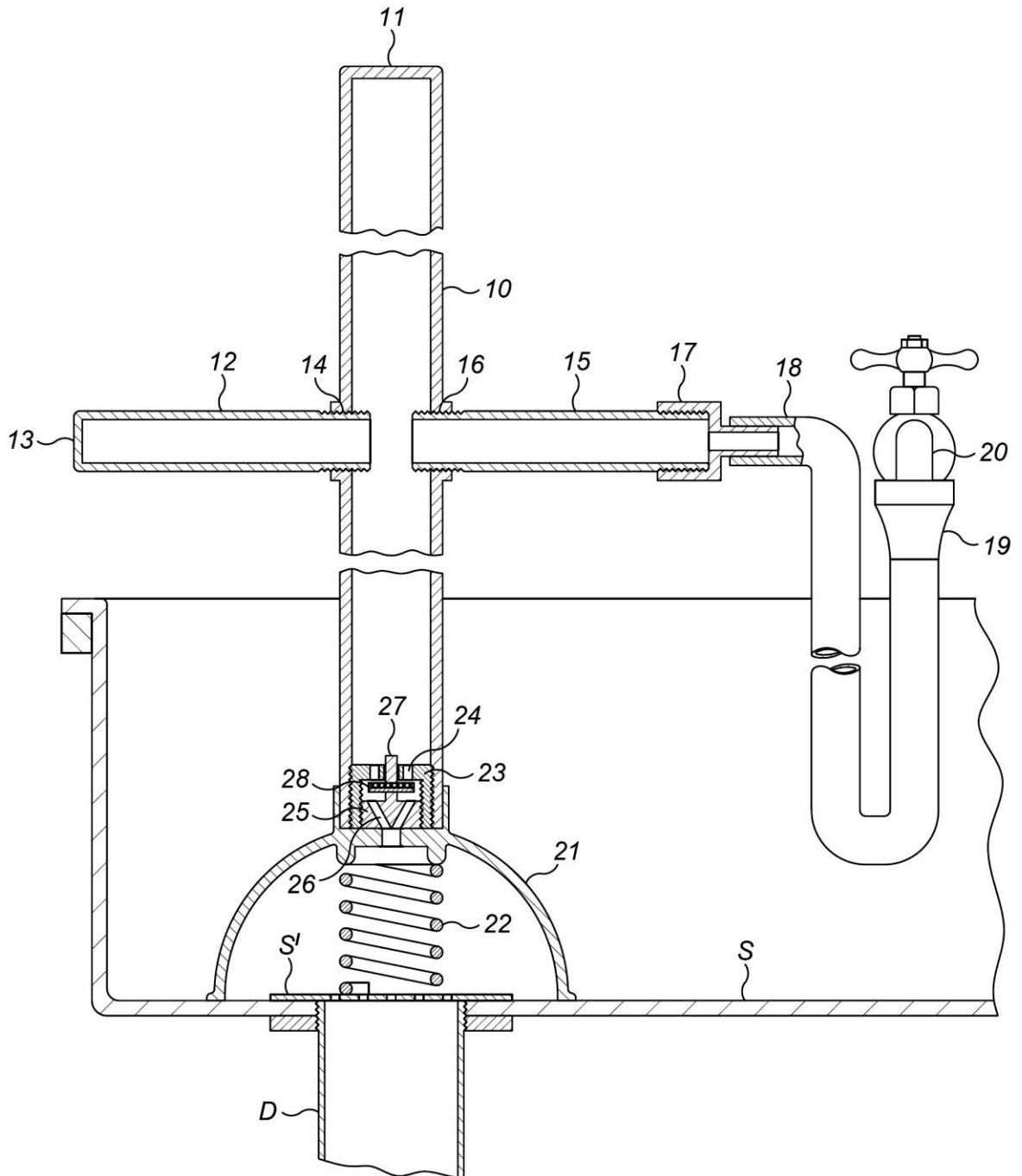

FIG. 1

Prior art reference D2

US 4,123,123
Granted June 27, 1998
Thunderball, Inc.

PLUNGER

This invention relates to a plunger, particularly to one provided with an air pressure ball for storing air to be forced into a clogged pipe or drain for clearing the clogged mass.

A conventional plunger, shown in **Figs. 1 and 2**, includes a suction cup 10 made of rubber
5 connected with a long handle 20. In use, the suction cup 10 is placed over the mouth of a clogged pipe or drain of a sink or toilet bowl as shown in Fig. 4 and is compressed and released repeatedly to produce a pressure/suction force to clear the blockage. However, this conventional device is limited in the force that it can apply, making it difficult to clear a blocked drain.

10 The main object of the invention is to apply compressed air suddenly to unblock a drain. A plunger according to the invention has a pressure ball under an upper block, a tubular shaft extending vertically down from the pressure ball to a lower end stopper threadedly connected to the lower end of the shaft. Air may be pumped into the pressure ball, e.g. by a compressor, and when it is full the user operates a trigger to pull up a connecting rod which
15 opens a valve at the top of the tubular shaft. The air stored in the pressure ball is then forced through the tubular shaft and out of the stopper into the clogged pipe.

Reference is now made to the accompanying drawings, wherein:

Fig. 1 is a perspective view of a conventional plunger;

Fig. 2 is a cross-sectional view of the conventional plunger, in operation;

20 Fig. 3 is an exploded perspective view of a plunger of the present invention, with the parts spread out in a vertical line, split for convenience into two as shown by the dot-dash line; and

Fig. 4 is a cross-sectional view of the plunger of the present invention, being operated.

A plunger of the invention, as shown in **Figs. 3 and 4**, includes as its main components an
25 upper block 1 with two arms, forming a handle, a rod-like actuator or trigger 2, a pressure ball 3 for storing compressed air, a connecting rod 4, a tubular shaft 5, and a lower end stopper 6.

Document D

The upper block 1 has an internally threaded collar 12 projecting from the lower side of the block, connecting it to an upper boss or cylindrical protrusion 31 on the pressure ball 3. The trigger 2 is pivotally mounted in the upper block 1, with its outer end extending under one of the arms.

- 5 The pressure ball 3 also has an integral tubular air inlet 33 provided on the right-hand side of its upper boss, a pressure gauge 34 fixed on the left side of the upper boss, and a lower boss 32. The lower boss 32 is screwed into the top of the shaft 5.

The top end 41 of the connecting rod 4 is pivotably connected to the trigger 2, and passes down through the upper boss 31, the ball 3 itself and its lower boss 32. A coil spring 43 is
10 fitted around the upper portion of the rod 4 to urge the rod downwards.

The lower end of the rod 4 is screwed into a cone-shaped stopper or valve seat 45. The tubular shaft 5 has a cone-shaped recess 52, with which the valve seat 45 engages to seal the upper end of a long passageway 53 formed in the shaft 5.

The lower end of the shaft is screwed to the lower end stopper 6, which has the form of a
15 solid circular cone, pointing downwards, but other shapes might be suitable for other applications, e.g. bulbous. A central hole 62 in the stopper communicates with the passageway 53 of the tubular shaft 5 for air to flow down towards the drain. The stopper will be made of rubber or similar material, possibly with a rigid annular backing plate or washer.

20 In use, referring to Fig. 2, the lower end stopper 6 is placed to seal the mouth of the clogged pipe or drain, and the air inlet 33 is connected to a compressor or an air pump. Then air is pumped through the air inlet 33 into the pressure ball 3, which stores the air under pressure.

Meanwhile, the rod 4 is biased by the coil spring 43, with the upper stopper 45 pressed against the cone-shaped recess 52, preventing the air in the pressure ball 3 from flowing
25 down. The user checks the pressure gauge 34 as the ball fills; when the pressure reaches the necessary value, the user pulls up the handle 2, separating the upper stopper 45 from the recess 52, so that the air in the pressure ball 3 suddenly flows through the passageway 53 of the tubular shaft 5 and the hole 62 of the lower end stopper 6, and then into the clogged pipe or drain. Thus, the blockage is removed.

(Claims omitted)

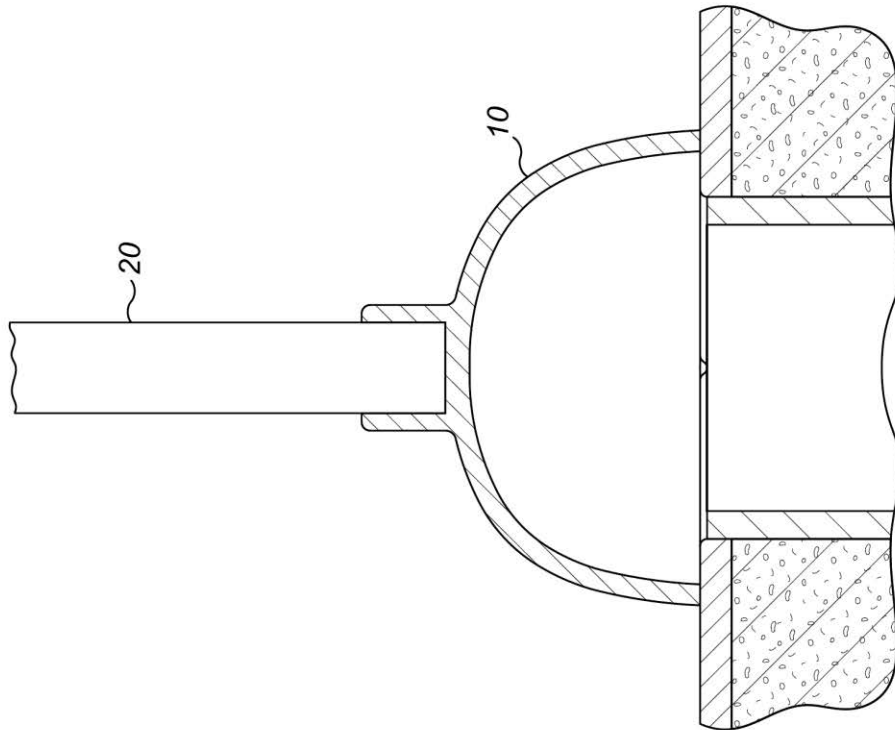

FIG. 2
(Prior art)

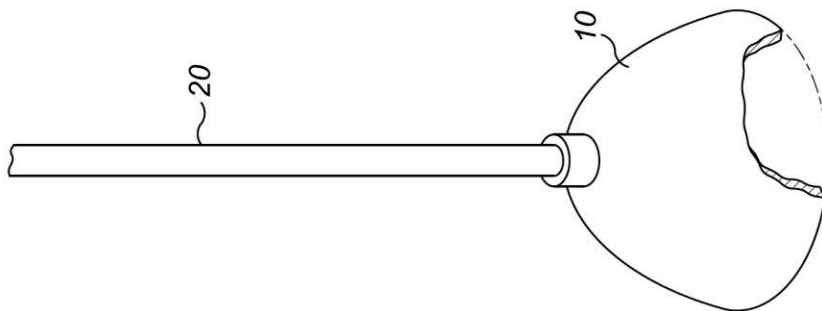

FIG. 1
(Prior art)

2 / 3

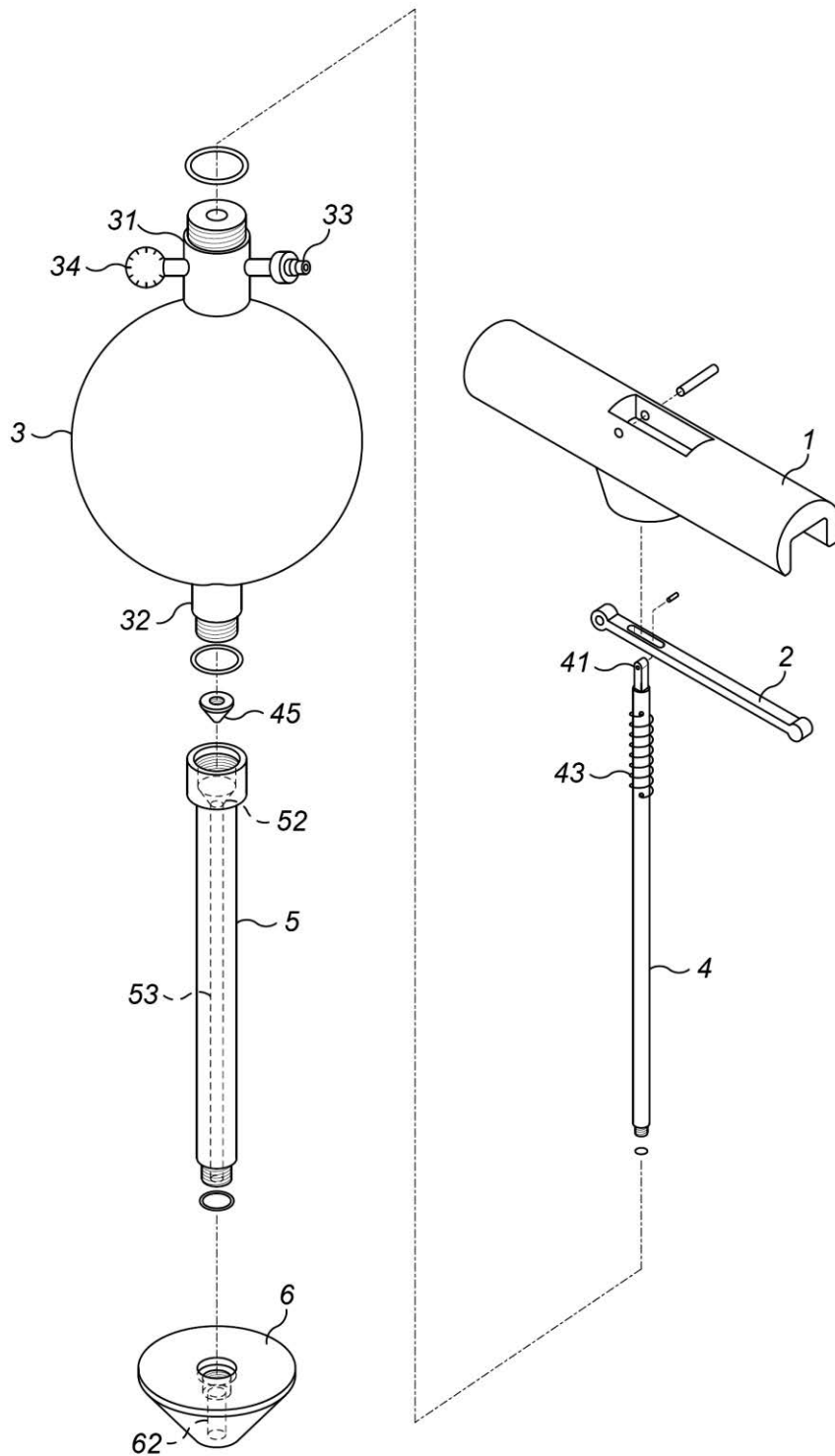

FIG. 3

3 / 3

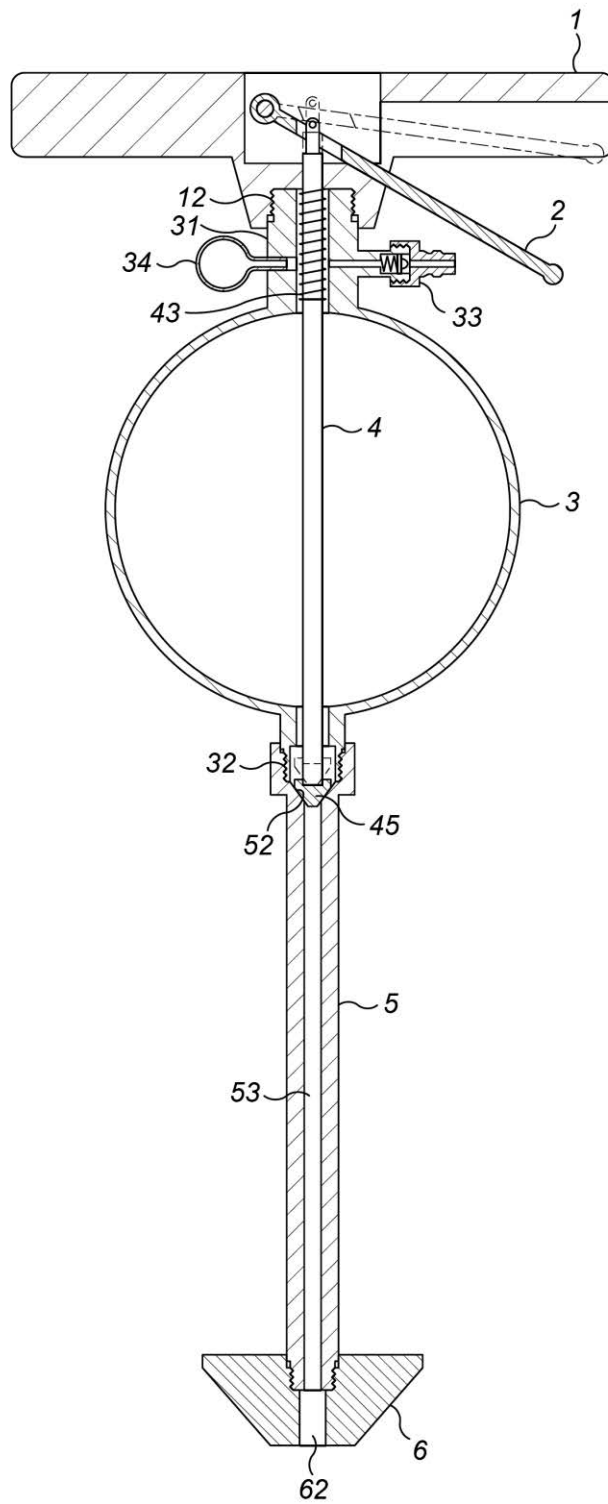

FIG. 4

Document E

A copy of the Claims

CLAIMS

1. A drain-clearing device comprising: a hemispherical drain sealing member (1) with a central passage (15), for sealing against a drain opening; and a water supply device (5) having an elongate pipe (13) secured to the sealing member and communicating with the central passage in the sealing member, a side arm (10) extending from an end of the pipe remote from the sealing member and communicating with the pipe for supplying water thereto, and a valve mounted in the pipe to control flow of fluid between the side arm and the central passage.
2. A drain-clearing device according to claim 1, in which the hemispherical drain sealing member (1) is made of resiliently compressible material for sealing against the drain opening and is fixedly attached to a solid, disc-like, annular member (2) with a threaded aperture aligned with the central passage (15).
3. A drain-clearing device according to claim 2, wherein the drain sealing member is made of rubber.
4. A drain-clearing device according to any preceding claim, wherein the elongate pipe (13) is made of plastics or metal.
5. A drain-clearing device according to any preceding claim, wherein the length of the pipe is in the range of 20-60 cm.

Document E

6. A drain-clearing device according to any preceding claim, wherein the side arm (10) has a thread for connection to a hose to be attached to a water supply.
7. A drain-clearing device according to claim 1, further comprising a spring (9) positioned around the stem (6') of the valve and in abutment with the end of the pipe for urging the stem out of the pipe.
8. A drain-clearing device according to claim 1, in which the valve is operable by the user to admit water.